

# \*TB 9-6625-2323-24

DEPARTMENT OF THE ARMY TECHNICAL BULLETIN

## CALIBRATION PROCEDURE FOR SIGNAL GENERATOR ANRITSU, MODEL 68369NV

Headquarters, Department of the Army, Washington, DC

1 July 2008

*Distribution Statement A: Approved for public release; distribution is unlimited.*

### REPORTING OF ERRORS AND RECOMMENDING IMPROVEMENTS

You can improve this manual. If you find any mistakes or if you know of a way to improve these procedures, please let us know. Mail your letter or DA Form 2028 (Recommended Changes to Publications and Blank Forms) directly to: Commander, U.S. Army Aviation and Missile Command, ATTN: AMSAM-MMC-MA-NP, Redstone Arsenal, AL 35898-5000. A reply will be furnished to you. You may also send in your comments electronically to our E-mail address: [2028@redstone.army.mil](mailto:2028@redstone.army.mil) or by fax 256-842-6546/DSN 788-6546. For the World Wide Web use: <https://amcom2028.redstone.army.mil>. Instructions for sending an electronic 2028 can be found at the back of this manual.

SECTION		Paragraph	Page
	I. IDENTIFICATION AND DESCRIPTION		
	Test instrument identification .....	1	2
	Forms, records, and reports .....	2	2
	Calibration description .....	3	2
	II. EQUIPMENT REQUIREMENTS		
	Equipment required .....	4	3
	Accessories required .....	5	4
	III. CALIBRATION PROCESS		
	Preliminary instructions .....	6	4
	Equipment setup .....	7	5
	Frequency accuracy .....	8	5
	Output level flatness .....	9	7
	Attenuator accuracy .....	10	8
	Spectral purity .....	11	11
	Amplitude modulation .....	12	12
	Frequency modulation .....	13	15
	Pulse modulation .....	14	18
	Final procedure .....	15	20

\*This bulletin supersedes TB 9-6625-2323-35, dated 31 May 2005, including all changes.

**SECTION I  
IDENTIFICATION AND DESCRIPTION**

**1. Test Instrument Identification.** This bulletin provides instructions for the calibration of Signal Generator, Anritsu, Model 68369NV. The manufacturer’s manual was used as the prime data source in compiling these instructions. The equipment being calibrated will be referred to as the TI (test instrument) throughout this bulletin.

**a. Model Variations.** None.

**b. Time and Technique.** The time required for this calibration is approximately 5 hours, using the dc and low frequency and microwave techniques.

**2. Forms, Records, and Reports**

**a.** Forms, records, and reports required for calibration personnel at all levels are prescribed by TB 750-25.

**b.** Adjustments to be reported are designated (R) at the end of the sentence in which they appear. When adjustments are in tables, the (R) follows the designated adjustment. Report only those adjustments made and designated with (R).

**3. Calibration Description.** TI parameters and performance specifications which pertain to this calibration are listed in table 1.

Table 1. Calibration Description

Test instrument parameters	Perform specifications
Frequency	Range: $\pm 10$ MHz to 40 GHz <sup>1</sup> Accuracy: $<\pm 5$ parts in $10^{-8}$ Time base stability: $<\pm 5$ parts in $10^{-8}$ per day
Harmonics: Harmonics 10 MHz to $\leq 50$ MHz $>50$ MHz to $\leq 2$ GHz $>2$ GHz to $\leq 20$ GHz $>20$ GHz to $\leq 40$ GHz <sup>1</sup>  Non-harmonic 10 MHz to $\leq 2$ GHz $>2$ GHz to $\leq 40$ GHz	$<-30$ dBc $<-40$ dBc $<-60$ dBc $<-40$ dBc  $<-40$ dBc $<-60$ dBc
RF output Level: 7 dBm  Flatness: 10.0 MHz to 50.0 MHz 50 MHz to 40 GHz <sup>1</sup>  Attenuator: 0 to $-122$ dB <sup>2</sup>	Accuracy: $\pm 1$ dB  Accuracy: $\pm 2$ dB for a 3 dB output level $\pm 0.8$ dB for a 7 dB output level  Accuracy: $\pm 1$ dB

Footnotes at end of table.

Table 1. Calibration Description - Continued

Test instrument parameters	Perform specifications
Pulse modulation Pulse rate:  Pulse on/off ratio:  Rise/fall time:  Overshoot:	DC to 10 MHz unleveled 100 Hz to 5 MHz leveled  Range: 10 MHz to 40 GHz <sup>1</sup> Accuracy: > 80 dB  < 10 nS  < 10%
Amplitude modulation: Depth:  Incidental PM:  Modulation frequency response:	10 MHz to 40 GHz <sup>1</sup> Range: 0 to 90% <sup>3</sup> Accuracy: ± 10 % of setting  < 0.2 radians 30% AM depth. 10 kHz mod freq  Range: DC to 10 kHz Accuracy: <0.3 dB
Frequency modulation: Unlocked FM mode:  Locked FM Mode:  Incidental AM:  Modulation Frequency Response:	Range: ± 100 MHz (DC to 100 Hz mod rate) <sup>4</sup> Accuracy: ±5%  Range: ± 10 MHz (DC to 8 MHz mod rate) <sup>5</sup> Accuracy: ±5%  Range: The lesser of ± 10 MHz or Fmod X 300 (1 kHz to 8 MHz mod rate) <sup>6</sup>  < 2% <sup>7</sup>  Range: 3 kHz to 8 MHz <sup>8</sup> Accuracy: <1 dB

<sup>1</sup>Not verified above 18 GHz.

<sup>2</sup>Verified to 90 dB.

<sup>3</sup>Verified at 50% depth, 1 kHz mod freq., 5 GHz carrier frequency.

<sup>4</sup>Verified at .1 Hz mod. rate, 100 MHz deviation.

<sup>5</sup>Verified at 100 kHz Mod rate, 240 kHz deviation.

<sup>6</sup>Verified at 1 kHz to 8 MHz mod rate, 240 kHz deviation.

<sup>7</sup>Verified at 500 kHz deviation, 200 kHz mod frequency.

<sup>8</sup>Verified from 3 kHz to 50 kHz.

## SECTION II EQUIPMENT REQUIREMENTS

**4. Equipment Required.** Table 2 identifies the specific equipment to be used in this calibration procedure. This equipment is issued with Secondary Transfer Calibration Standards Set AN/GSM-287 or AN/GSM-705. Alternate items may be used by the calibrating activity. The items selected must be verified to perform satisfactorily prior to use and must bear evidence of current calibration. The equipment must meet or exceed the minimum use specifications listed in table 2. The accuracies listed in table 2 provide a four-to-one ratio between the standard and TI. Where the four-to-one ratio cannot be met, the actual accuracy of the equipment selected is shown in parenthesis.

**5. Accessories Required.** The accessories required for this calibration are common usage accessories, issued as indicated in paragraph 4 above, and are not listed in this calibration procedure. The following peculiar accessory is required: Radio Frequency Detector, Hewlett-Packard, Model HP-423A.

Table 2. Minimum Specifications of Equipment Required

Common name	Minimum use specifications	Manufacturer and model (part number)
AUDIO ANALYZER	Range: 1.0 to 100.0 kHz Accuracy: <2.0%	Boonton, Model 1121 (1121)
FREQUENCY DIFFERENCE METER	Range: 10 MHz Resolution: 1 part in 10 <sup>-8</sup>	Tracor, Model 527E (MIS-10318)
MEASURING RECEIVER	Range: 2.0 to 18 GHz Range: +11 to -74.5 dBm Accuracy: +.5 dB Range: AM 0 to 80% Accuracy: ±2% at 1 kHz Range: FM .05 to 100 kHz Accuracy: ±2% at 1 kHz Deviation: ± 12 kHz	Measuring receiver system N5531S consisting of: Spectrum Analyzer, Agilent Model E4440A (E4440A), Power meter, Agilent Model E4419B (E4419B), and Sensor module, Agilent Model 518 (518)
MICROWAVE FREQUENCY COUNTER	Range: 10 MHz to 18 GHz Accuracy: <sup>1</sup>	Anritsu, Model MF2414B003 (MF2414B003)
OSCILLOSCOPE	Range: 5.0 V at 100 ns Accuracy: 3.0%	(OS-303/G)
SPECTRUM ANALYZER	Range: 2 to 18 GHz at +10 to -60 dBm Accuracy: ±0.2% of the center frequency +20% of the span/div Range: Span 500 Hz to 20 MHz Accuracy: ±5%	(AN/USM-677)
TIME/FREQUENCY WORKSTATION	Frequency: 1 MHz Accuracy: 5 parts in 10 <sup>-10</sup> per day	Datum, Model ET6000-75 (13589305)

<sup>1</sup>Time base locked to the TI.

### SECTION III CALIBRATION PROCESS

#### 6. Preliminary Instructions

a. The instructions outlined in paragraphs 6 and 7 are preparatory to the calibration process. Personnel should become familiar with the entire bulletin before beginning the calibration.

b. Items of equipment used in this procedure are referenced within the text by common name as listed in table 2.

c. Unless otherwise specified, verify the result of each test and, whenever the test requirement is not met, take corrective action before continuing with the calibration. Adjustments required to calibrate the TI are included in this procedure. Additional maintenance information is contained in the manufacturer's manual and ST400-AW-MMC-020 and ST400-HW-MMC-030 for this TI.

d. Unless otherwise specified, all controls and control settings refer to the TI.

## 7. Equipment Setup

### WARNING

HIGH VOLTAGE is used or exposed during the performance of this calibration. DEATH ON CONTACT may result if personnel fail to observe safety precautions. REDUCE OUTPUT(s) to minimum after each step within the performance check where applicable.

- a. Remove TI protective cover only as necessary to make adjustments.

### CAUTION

Before connecting TI to power source, make sure TI is set to the power source line voltage as shown on rear of TI.

- b. Connect TI to 115 V ac power source.
- c. Press **LINE** switch to **OPERATE** and allow at least one hour for TI to warm-up and stabilize.
- d. Connect equipment as shown in figure 1.

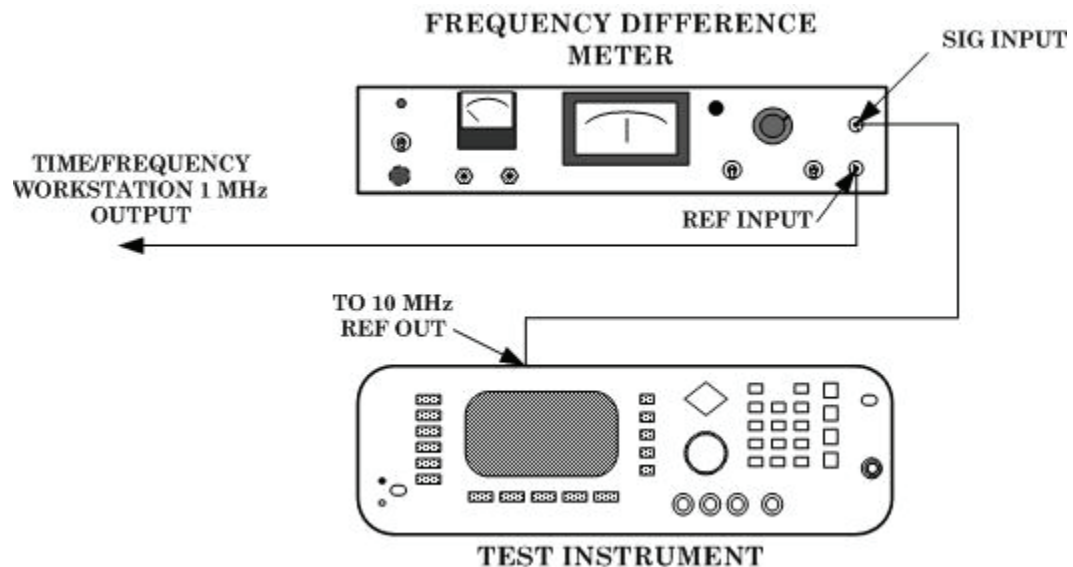

Figure 1. Time base verification hook-up.

### NOTE

TI must have power applied and in **STANDBY** or **OPERATE** for at least 120 continuous hours before the frequency drift specification can be verified.

- e. Verify that the frequency difference meter drift is less than  $\pm 5$  parts in  $10^{-8}$  per day.
- f. Disconnect frequency difference meter from the TI and the time/frequency workstation.

## 8. Frequency Accuracy

### a. Performance Check

- (1) Connect equipment as indicated in figure 2.

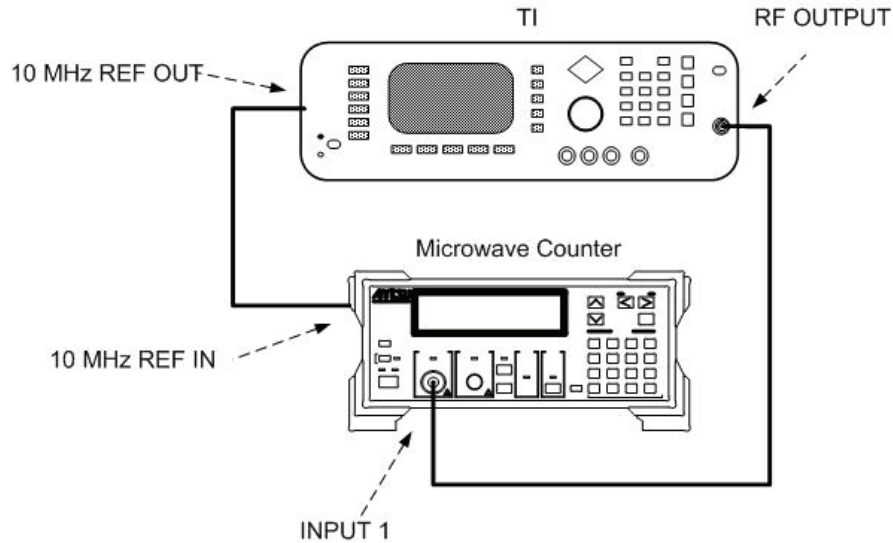

Figure 2. Frequency resolution accuracy hook-up.

- (2) Press TI keys as listed in (a) through (e) below.
  - (a) **System, Reset.**
  - (b) **Output On Off** to off.
  - (c) **Level Control, L0, Edit L0, 0,** and **MHz ms dB.**
  - (d) **Frequency Control, F0, Edit F0, 1,** and **GHz Sec dBm.**
  - (e) **Output On Off** to on.
- (3) Set microwave frequency counter to measure frequency on **INPUT 1**.
- (4) Verify that the microwave frequency counter indicates within limits listed in table 3.
- (5) Set TI frequency to the next frequency listed in table 3, using the TI arrow pad, and repeat (4) above.
- (6) Repeat (4) and (5) above for the remaining frequencies listed in table 3.

Table 3. Frequency Resolution Accuracy

Test instrument center frequency (GHz)	Microwave frequency counter indications	
	Min (Hz)	Max (Hz)
1.000000000	999999990	1000000010
1.000000100	1000000090	1000000110
1.000000200	1000000190	1000000210
1.000000300	1000000290	1000000310
1.000000400	1000000390	1000000410
1.000000500	1000000490	1000000510
1.000000600	1000000590	1000000610
1.000000700	1000000690	1000000710
1.000000800	1000000790	1000000810
1.000000900	1000000890	1000000910
1.000001000	1000000990	1000001010

Table 3. Frequency Resolution Accuracy - Continued

Test instrument center frequency (GHz)	Microwave frequency counter indications	
	Min (Hz)	Max (Hz)
2.000000000	1999999990	2000000010
2.000001000	2000000990	2000001010
2.000002000	2000001990	2000002010
2.000003000	2000002990	2000003010
2.000004000	2000003990	2000004010
2.000005000	2000004990	2000005010
2.000006000	2000005990	2000006010
2.000007000	2000006990	2000007010
2.000008000	2000007990	2000008010
2.000009000	2000008990	2000009010
2.000010000	2000009990	2000010010
3.000000000	2999999990	3000000010
4.000000000	3999999990	4000000010
5.000000000	4999999990	5000000010
6.000000000	5999999990	6000000010
7.000000000	6999999990	7000000010
8.000000000	7999999990	8000000010
9.000000000	8999999990	9000000010
10.000000000	9999999990	10000000010
11.000000000	10999999990	11000000010
12.000000000	11999999990	12000000010
13.000000000	12999999990	13000000010
14.000000000	13999999990	14000000010
15.000000000	14999999990	15000000010
16.000000000	15999999990	16000000010
17.000000000	16999999990	17000000010
18.000000000	17999999990	18000000010

(7) Reduce all outputs to minimum.

(8) Disconnect microwave frequency counter from TI.

**b. Adjustments.** No adjustments can be made.

## 9. Output Level Flatness

### a. Performance Check

(1) Connect power sensor module to measuring receiver **POWER REF** output.

(2) Zero and calibrate the power sensor.

(3) Disconnect the power sensor module from the measuring receiver **POWER REF** output and connect it to the TI **RF OUTPUT**.

(4) Press TI keys as listed in (a) through (e) below:

(a) **System, Reset.**

(b) **Output On Off** to off.

(c) **Level Control, L1, Edit L1, 7, and MHz ms dB.**

(d) **Output On Off** to on.

(e) **Frequency Control, F0, Edit F0, 1, and GHz Sec dBm.**

(5) Using measuring receiver and RF power techniques in Log Mode, sweep the TI from 2 GHz to 18 GHz in 1 GHz steps and record the highest and lowest levels.

(6) Calculate the flatness using the formula below. The flatness will be less than or equal to the maximum limit listed in table 4.

$$\text{Flatness} = (\text{highest} - \text{lowest}) / 2$$

Table 4. Output Level Flatness

Start frequency	Stop frequency	Max limit (dB)
2 GHz	18 GHz	0.799

**b. Adjustments.** No adjustments can be made.

## 10. Attenuator Accuracy

### a. Performance Check

- (1) Connect power sensor module to measuring receiver **POWER REF** output.
- (2) Zero and calibrate the power sensor.
- (3) Disconnect the measuring receiver power sensor module from the measuring receiver **POWER REF** output and connect it to the **TI RF OUTPUT**.

(4) Press TI keys as listed in (a) through (e) below:

- (a) **System, Reset.**
- (b) **Output On Off** to off.
- (c) **Frequency Control, F0, Edit F0, 2, and GHz Sec dBm.**
- (d) **Output On Off** to on.
- (e) **Level Control, L1, Edit L1, 0, and MHz ms dB.**

(5) Using measuring receiver and RF power techniques in Log Mode verify that the measuring receiver indicates within tolerances listed in table 5.

(6) Using technique of (4) (e) set the TI to the remaining levels listed in table 5 and repeat (5) above.

Table 5. 2 GHz Output Level Test 1 dB Steps

Test instrument output level (dB)	Measuring receiver Min (dB)	Measuring receiver Max (dB)
0	-1	1
-1	-2	0
1	0	2
2	1	3
3	2	4

(7) Press **Level Control, L1, Edit L1, 0, and MHz ms dB.**

(8) Using standard tuned level measurement techniques, verify the measuring receiver indicates within minimum and maximum limits for TI output level as listed in table 6 below.

(9) Use the TI arrow key to decrement the output level 10 dB, as indicated in table 6, verifying the indication is within limits listed in table 6.



(10) Repeat (9) above for remaining TI output level settings listed in table 6.

Table 6. 2 GHz Output Level Test 10 dB Steps

Test instrument output level (dB)	Measuring receiver Min (dB)	Measuring receiver Max (dB)
0	-1	1
-10	-11	-9
-20	-21	-19
-30	-31	-29
-40	-41	-39
-50	-51	-49
-60	-61	-59
-70	-71	-69
-80	-81	-79
-90	-91	-89

(11) Press TI keys as listed in (a) and (b) below:

(a) **Frequency Control, F0, Edit F0, 5, and GHz Sec dBm.**

(b) **Level Control, L1, Edit L1, 0, and MHz ms dB.**

(12) Using measuring receiver and RF power techniques in Log Mode verify that the measuring receiver indicates within tolerances listed in table 7.

(13) Using TI arrow key set the TI to the remaining levels listed in table 7 and repeat (12) above.

Table 7. 5 GHz Output Level Test 1 dB Steps

Test instrument output level (dB)	Measuring receiver Min (dB)	Measuring receiver Max (dB)
0	-1	1
-1	-2	0
1	0	2
2	1	3
3	2	4

(14) Press **Level Control, L1, Edit L1, 0, and MHz ms dB.**

(15) Using standard tuned level measurement techniques verify the measuring receiver indicates within minimum and maximum limits for TI output level as listed in table 8 below.

(16) Use the TI arrow key to decrement the output level as indicated in table 8 and repeat (15) above.

(17) Repeat (16) above for remaining TI output level settings listed in table 8.

Table 8. 5 GHz Output Level Test 10 dB Steps

Test instrument output level (dB)	Measuring receiver Min (dB)	Measuring receiver Max (dB)
0	-1	1
-10	-11	-9
-20	-21	-19
-30	-31	-29

Table 8. 5 GHz Output Level Test 10 dB Steps - Continued

Test instrument output level (dB)	Measuring receiver Min (dB)	Measuring receiver Max (dB)
-40	-41	-39
-50	-51	-49
-60	-61	-59
-70	-71	-69
-80	-81	-79
-90	-91	-89

(18) Press TI keys as listed in (a) through (b) below:

(a) **Frequency Control, F0, Edit F0, 18, and GHz Sec dBm.**

(b) **Level Control, L1, Edit L1, 0, and MHz ms dB.**

(19) Using measuring receiver and RF power techniques in log mode verify that the measuring receiver indicates within tolerances listed in table 9.

(20) Using TI arrow key set the TI to the remaining levels listed in table 9 and repeat (19) above.

Table 9. 18 GHz Output Level Test 1 dB Steps

Test instrument output level (dB)	Measuring receiver Min (dB)	Measuring receiver Max (dB)
0	-1	1
-1	-2	0
1	0	2
2	1	3
3	2	4

(21) Press Level Control, L1, Edit L1, 0, and MHz ms dB.

(22) Using standard tuned level measurement techniques, verify the measuring receiver indicates within minimum and maximum limits for TI output level as listed in table 10 below.

(23) Use the TI arrow key to decrement the output level as indicated in table 10 and repeat (22) above.

(24) Repeat (23) above for remaining TI output level settings listed in table 10.

Table 10. 18 GHz Output Level Test 10 dB Steps

Test instrument output level (dB)	Measuring receiver Min (dB)	Measuring receiver Max (dB)
0	-1	1
-10	-11	-9
-20	-21	-19
-30	-31	-29
-40	-41	-39
-50	-51	-49
-60	-61	-59
-70	-71	-69
-80	-81	-79
-90	-91	-89

- (25) Reduce TI output to minimum.
- (26) Disconnect TI from measuring receiver.

**b. Adjustments.** No adjustments can be made.

## 11. Spectral Purity

### a. Performance Check

- (1) Connect equipment as shown in figure 3.

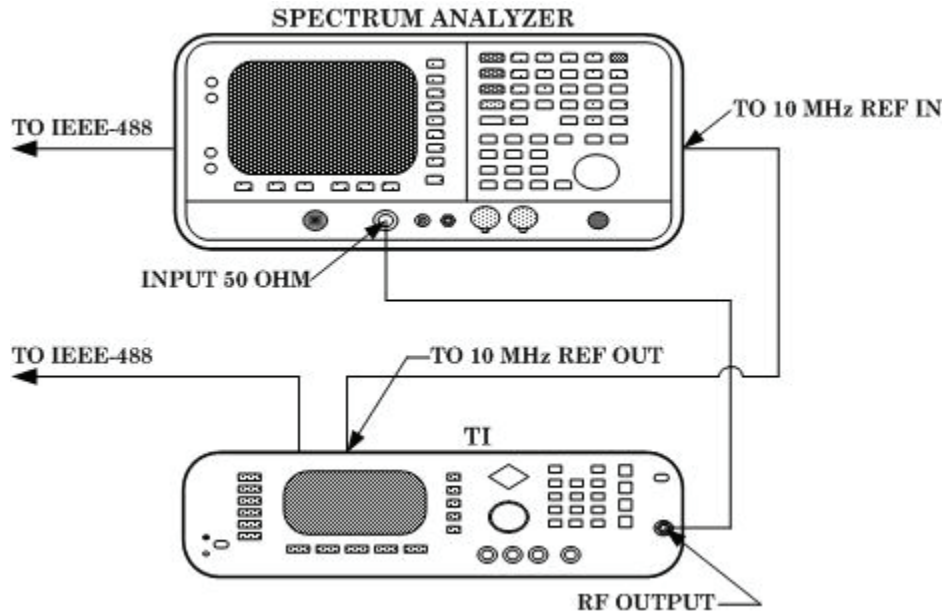

Figure 3. Spectral purity hook-up.

- (2) Press TI keys as listed in (a) through (e) below.
  - (a) **System, Reset.**
  - (b) **Output On Off** to off.
  - (c) **Level Control, L1, Edit L1, 3, and MHz ms dB.**
  - (d) **Frequency Control, F0, Edit F0, 1, 0, and MHz ms dB.**
  - (e) **Output On Off** to on.
- (3) Set the spectrum analyzer controls as listed in (a) through (e) below.
  - (a) **Span X Scale** to 1, 0, MHz.
  - (b) **FREQUENCY Channel, Center Frequency** to 1, 0, MHz.
  - (c) **BW/Avg, Res BW** to 1, MHz.
  - (d) **Sweep, Sweep Time** to Auto.
  - (e) **Amplitude Y Scale, Ref Level**, 1, 0, dBm.
- (4) On the spectrum analyzer measure the worst case harmonic and non-harmonic signals for the frequencies listed in table 11 and verify that TI is less than or equal to the maximum indications listed.

Table 11. Spectral Purity

Test instrument frequency	Spectrum analyzer reference frequency	Harmonic frequency	Maximum indication
10 MHz	10 MHz	-----	6
10 MHz	10 MHz	20 MHz	-30
10 MHz	10 MHz	30 MHz	-30
20 MHz	20 MHz	-----	6
20 MHz	20 MHz	40 MHz	-30
20 MHz	20 MHz	60 MHz	-30
30 MHz	30 MHz	-----	6
30 MHz	30 MHz	60 MHz	-30
30 MHz	30 MHz	90 MHz	-30
40 MHz	40 MHz	-----	6
40 MHz	40 MHz	80 MHz	-30
40 MHz	40 MHz	120 MHz	-30
350 MHz	350 MHz	-----	6
350 MHz	350 MHz	700 MHz	-40
350 MHz	350 MHz	1050 MHz	-40
1.6 GHz	1.6 GHz	-----	6
1.6 GHz	1.6 GHz	3.2 GHz	-40
1.6 GHz	1.6 GHz	4.8 GHz	-40
2.1 GHz	2.1 GHz	-----	6
2.1 GHz	2.1 GHz	4.2 GHz	-60
2.1 GHz	2.1 GHz	6.3 GHz	-60
2.1 GHz	2.1 GHz	8.4 GHz	-60
2.1 GHz	2.1 GHz	10.5 GHz	-60
2.1 GHz	2.1 GHz	12.6 GHz	-60
2.1 GHz	2.1 GHz	14.7 GHz	-60
2.1 GHz	2.1 GHz	16.8 GHz	-60
3.6 GHz	3.6 GHz	-----	6
3.6 GHz	3.6 GHz	7.2 GHz	-60
3.6 GHz	3.6 GHz	10.8 GHz	-60
3.6 GHz	3.6 GHz	14.4 GHz	-60
3.6 GHz	3.6 GHz	18.0 GHz	-60
7.0 GHz	7.0 GHz	-----	6
7.0 GHz	7.0 GHz	14.0 GHz	-60

- (5) Reduce all outputs to minimum.
- (6) Disconnect TI from spectrum analyzer.

**b. Adjustments.** No further adjustments can be made.

**12. Amplitude Modulation**

**a. Performance Check**

- (1) Connect equipment as shown in figure 4.
- (2) Set audio analyzer controls as listed in (a) through (d) below.
  - (a) **PRGM 99 ENTER RCL.**
  - (b) 600 Ω output.
  - (c) **SOURCE FREQ** to 1, kHz.
  - (d) **SOURCE LEVEL** to 0.7, V.

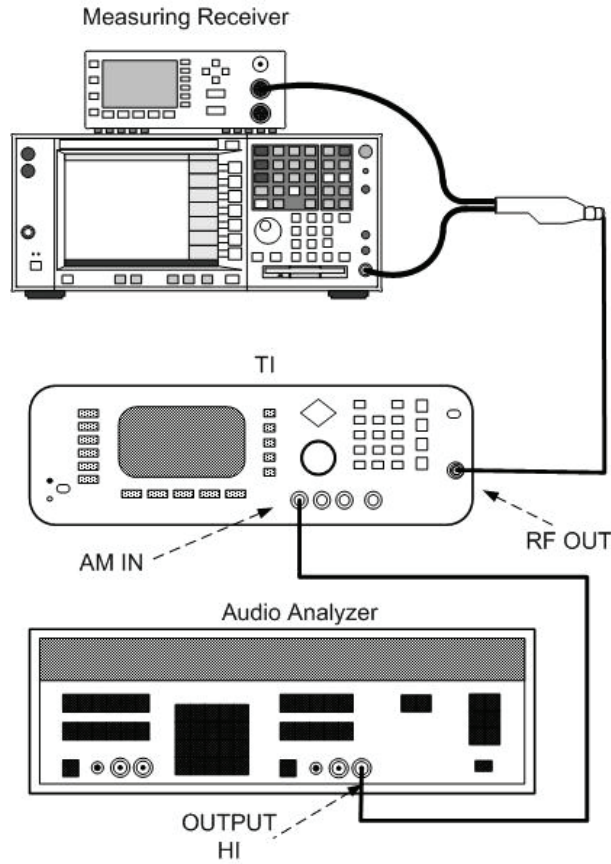

Figure 4. Amplitude modulation hook-up.

- (3) Set measuring receiver to measure amplitude modulation, with **+PEAK** detector, 300 Hz high pass and 3 kHz lo pass filters.
- (4) Press TI keys as listed in (a) through (i) below.
  - (a) **System, Reset.**
  - (b) **Output On Off** to off.
  - (c) **Level Control, L1, Edit L1, -3, and MHz ms dB.**
  - (d) **Frequency Control, F0, Edit F0, 5, and GHz Sec dBm.**
  - (e) **Output On Off** to on.
  - (f) **Modulation, AM, More, Log/Linear** to display **Depth** in %, and **Previous Menu.**
  - (g) **Edit Depth, 5, 0, Edit Depth.**
  - (h) **Mod. Wave**, press arrow key to highlight sine wave, press **Select**, and **Previous Menu.**
  - (i) **Edit Rate, 1, kHz  $\mu$ s Step, and Edit Rate.**
- (5) Verify that the measuring receiver indicates within 50% AM @ 5 GHz limits listed in table 12.
- (6) Press TI keys as listed in (a) through (d) below.

- (a) **Modulation, AM, More, Log/Linear** to display **Depth** in %, and **Previous Menu**.
- (b) **Edit Depth, 3, 0, Hz ns Adrs, Edit Depth**.
- (c) **Mod Wave**, press arrow key to highlight **sine wave**, press **Select**, and **Previous Menu**.
- (d) **Edit Rate, 1, 0, kHz  $\mu$ s Step, and Edit Rate**.
- (7) Set measuring receiver to measure phase modulation, with **+PEAK** detector.
- (8) Verify that the measuring receiver indicates within Incd. PM @ 5 GHz limits listed in table 12.

Table 12. AM Meter

Test description	Measuring receiver indication	
	Min (%)	Max (%)
50% AM @ 5 GHz	45.0	55.0
Incd. PM @ 5 GHz	0.001	0.2

- (9) Set measuring receiver to measure amplitude modulation, with **+PEAK** detector, high pass filter to <20 Hz, and lo pass filter to >20 kHz.
- (10) Press TI keys as listed in (a) through (h) below.
  - (a) **Frequency Control, F0, Edit F0, 5, and GHz Sec dBm**.
  - (b) **Level Control, L1, Edit L1, -3, and MHz ms dB**.
  - (c) **Modulation, AM, More, Int/Ext** to select **External AM Status**.
  - (d) **Output On Off** to on.
  - (e) **More, Log/Linear** to display **Sensitivity** in **dB**, and **Previous Menu**.
  - (f) **Front/Rear** to display **Source Front**.
  - (g) **600  $\Omega$ /50  $\Omega$**  to display **Impedance 600  $\Omega$** .
  - (h) **Edit Sens, 6, MHz ms dB, and Edit Sens**.
- (11) Set audio analyzer controls as listed in (a) through (c) below.
  - (a) **SOURCE FREQ** to **30 Hz**.
  - (b) **SOURCE LEVEL** to **1, V**.
  - (c) Impedance to 600  $\Omega$ .
- (12) Set the measuring receiver to AM in Ratio mode.
- (13) Verify that the measuring receiver indicates within limits listed in table 13.
- (14) Set the audio analyzer output frequency to the values listed in table 13 and repeat (13) above.

Table 13. External AM Frequency Response

Test description	Audio analyzer output frequency (Hz)	Measuring receiver indication	
		Min (dB)	Max (dB)
100 Hz Response	100	-0.3	0.3
1 kHz Response	1000	-0.3	0.3
2 kHz Response	2000	-0.3	0.3
5 kHz Response	5000	-0.3	0.3
10 kHz Response	10000	-0.3	0.3

(15) Reduce all outputs to minimum.

(16) Disconnect equipment setup.

**b. Adjustments.** No further adjustments can be made.

### 13. Frequency Modulation

#### a. Performance Check

(1) Connect equipment as shown in figure 5.

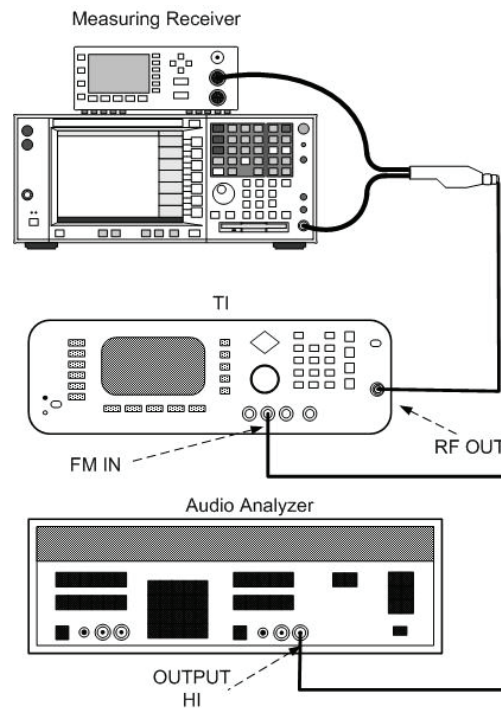

Figure 5. Frequency modulation hook-up.

(2) Set measuring receiver to measure frequency modulation, with **+PEAK** detector, **<20 Hz** high pass and **>200 kHz** lo pass filters.

(3) Press TI keys as listed in (a) through (j) below.

(a) **System, Reset.**

(b) **Output On Off** to off.

(c) **Level Control, L1, Edit L1, 0, and MHz ms dB.**

- (d) **Frequency Control, F0, Edit F0, 5, and GHz Sec dBm.**
  - (e) **Output On Off** to on.
  - (f) **Modulation, FM, More, FM Modes, Locked, Previous Menu, Previous Menu.**
  - (g) **Edit Dev., 2, 4, 0, kHz  $\mu$ s Step, Edit Dev.**
  - (h) **Mod. Wave**, arrow key to  $\sim$ , **Select, Previous Menu.**
  - (i) **Edit Rate, 1, 0, 0, kHz  $\mu$ s Step, Edit Rate.**
  - (j) **On/Off** to on.
- (4) Verify that the measuring receiver indication is within 240 kHz FM locked limits listed in table 14.
- (5) Set audio analyzer controls as listed in (a) through (d) below.
- (a) **PRGM 99 ENTER RCL.**
  - (b) 600  $\Omega$  output.
  - (c) **SOURCE FREQ** to **25 kHz.**
  - (d) **SOURCE LEVEL** to **1, V.**
- (6) Press TI keys as listed in (a) through (f) below.
- (a) **On/Off** to off.
  - (b) **More, Int/Ext** to **Ext.**
  - (c) **Front/Rear** to front.
  - (d) **600  $\Omega$ /50  $\Omega$**  to display **Impedance 600  $\Omega$ .**
  - (e) **Edit Sens, 1, 0, 0, kHz  $\mu$ s Step.**
  - (f) **On/Off** to on.
- (7) Set the measuring receiver to FM Ratio mode.
- (8) Set the audio analyzer to remaining frequencies listed in table 14, and verify that the measuring receiver indicates within limits listed in table 14.

Table 14. FM Deviation Locked and Response

Test description	Audio analyzer output frequency (Hz)	Measuring receiver indication	
		Min	Max
240 kHz FM Locked		228.00 kHz	252.00 kHz
25 kHz Reference	25000	----	----
3 kHz Response	3000	-1 dB	1 dB
10 kHz Response	10000	-1 dB	1 dB
20 kHz Response	20000	-1 dB	1 dB
30 kHz Response	30000	-1 dB	1 dB
40 kHz Response	40000	-1 dB	1 dB
50 kHz Response	50000	-1 dB	1 dB

- (9) Press TI keys as listed in (a) through (h) below.
- (a) **On/Off** to off.
  - (b) **More, Int/Ext** to **Int.**
  - (c) **Front/Rear** to front.



- (d) **More, FM Modes, Locked, Previous Menu, Previous Menu.**
  - (e) **Edit Dev., 2, 4, 0, kHz  $\mu$ s Step, Edit Dev.**
  - (f) **Mod Wave, arrow key to ~, Select, Previous Menu.**
  - (g) **Edit Rate, 1, 0, kHz  $\mu$ s Step, Edit Rate.**
  - (h) **On/Off** to on.
- (10) Set the measuring receiver for a modulation distortion measurement.
- (11) Verify that the measuring receiver distortion indication is less than the maximum indication listed in table 15 for Distortion @ 240 kHz Dev.
- (12) Press TI keys as listed in (a) and (b) below.
- (a) **More, FM Modes, Unlocked Narrow, Previous Menu, Previous Menu.**
  - (b) **Edit Rate, 1, 0, kHz  $\mu$ s Step, Edit Rate.**
- (13) Set the measuring receiver HP filter to **300 Hz**.
- (14) Verify that the measuring receiver indication is within the limits listed in table 15 for 240 kHz FM unlocked.
- (15) Press TI keys as listed in (a) and (b) below.
- (a) **More, FM Modes, Locked, Previous Menu, Previous Menu.**
  - (b) **Edit Rate, 2, 0, 0, kHz, Edit Rate.**
- (16) Set the measuring receiver HP filter to **50 Hz**, LP filter to **>20 kHz**, and set to measure **AM**.
- (17) Verify that the measuring receiver indication is less than the maximum limit listed in table 15 for Incidental AM @ 5 GHz.

Table 15. FM Meter

Test description	Measuring receiver indication	
	Min	Max
Distortion @ 240 kHz Dev	----	1 %
240 kHz FM unlocked	228 kHz	252 kHz
Incidental AM @ 5 GHz	----	2 %

- (18) Disconnect equipment setup and reconnect equipment as shown in figure 3.
- (19) Press TI keys as listed in (a) through (k) below.
- (a) **System, Reset.**
  - (b) **Output On Off** to off.
  - (c) **Level Control, L1, Edit L1, 0, and MHz ms dB.**
  - (d) **Frequency Control, F0, Edit F0, 5, and GHz Sec dBm.**
  - (e) **Output On Off** to on.
  - (f) **Modulation, FM, More, FM Modes, UnLocked Wide, Previous Menu, Previous Menu.**
  - (g) **Mod Wave, arrow key to highlight square wave, Select, Previous Menu.**
  - (h) **Edit Dev., 1, 0, 0, MHz ms dB, Edit Dev.**
  - (i) **Edit Rate, 0, ., 4, Hz ns Adrs, Edit Rate.**

- (j) **On/Off** to on.
- (k) **FM**.
- (20) Set spectrum analyzer **Center Freq** to **5, GHz**.
- (21) Set the spectrum analyzer **Span** to **5 MHz** and adjust the center frequency control to position the low carrier at the center of the display. Record the frequency reading.
- (22) Adjust the center frequency counter to position the high carrier at the center of the display. Record the frequency reading.
- (23) Verify that the difference between the value recorded in (21) above and (22) above is within the limits listed in table 16.

Table 16. Peak to Peak Frequency Deviation

Test description	Spectrum analyzer indication	
	Min	Max
200 MHz Pk to Pk dev.	190.000 M	210.000 M

- (24) Reduce outputs to minimum.
- (25) Disconnect equipment setup.
- b. Adjustments.** No further adjustments can be made.

**14. Pulse Modulation**

**a. Performance Check**

- (1) Connect equipment as shown in figure 6.

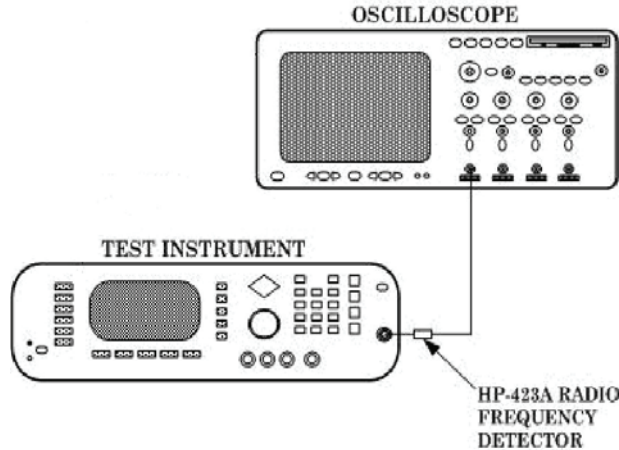

Figure 6. Pulse modulation hook-up.

- (2) Press TI keys as listed in (a) through (k) below.
  - (a) **System, Reset.**
  - (b) **Output On Off** to off.
  - (c) **Level Control, L1, Edit L1, 7, and MHz ms dB.**
  - (d) **Frequency Control, F0, Edit F0, 5, and GHz Sec dBm.**
  - (e) **Output On Off** to on.
  - (f) **Modulation, Pulse, and On/Off** to on.

- (g) **More, Config, Clock 40/10** to **40**.
  - (h) **Top Menu, More, Mode**, press arrow key to highlight **Single, Select**, and **Previous Menu**.
  - (i) **Trigger**, press arrow key to highlight **Free Run, Select**, and **Previous Menu**.
  - (j) **Previous Menu, Edit Period, 1, 0, kHz us Step, Edit Period**.
  - (k) **W/D List, Edit, 5, kHz us Step**, and **Edit**.
- (3) Set oscilloscope as listed in (a) through (f) below.
- (a) **Vertical 1 Input 50Ω** to on (lit).
  - (b) **Vertical 1** scale to **20 mV**.
  - (c) **Trigger Source** to **1**.
  - (d) **Trigger Sweep** to **Auto**.
  - (e) **Trigger Slope** to .
  - (f) **Horizontal** sweep speed to **10 nS**.
- (4) Measure rise time and verify that the oscilloscope indication is less than the rise time limit listed in table 17.
- (5) Select the remaining oscilloscope measurement types listed in table 17 and repeat (4) above for the appropriate type.

Table 17. Pulse Characteristics

Oscilloscope measurement type	Maximum indication
Rise Time	10 nS
Overshoot	10 %
Fall Time	10 nS

- (6) Disconnect equipment setup and reconnect as shown in figure 3.
- (7) Press TI keys as listed in (a) through (e) below.
- (a) **System, Reset**.
  - (b) **Output On Off** to off.
  - (c) **Level Control, L1, Edit L1, 0, dB**, and **Edit L1**.
  - (d) **Frequency Control, F0, Edit F0, 1**, and **GHz Sec dBm, Edit F0**.
  - (e) **Output On Off** to on.
- (8) Set spectrum analyzer as listed in (a) through (j) below.
- (a) **Preset**.
  - (b) **AMPLITUDE Y Scale, Ref Level, 1, 0, dBm**.
  - (c) **FREQUENCY Channel, Center Freq, 1, GHz**.
  - (d) **BW/Avg, Video BW** to **Auto**.
  - (e) **Res BW** to **Auto**.
  - (f) **SPAN X Scale, 1, MHz**.
  - (g) **Peak Search**.
  - (h) **Marker→, Mkr→ CF**.

- (i) **Mkr**→ **Ref Lvl**.
  - (j) **SPAN X Scale, 0, Hz**.
- (9) Press TI keys as listed in (a) through (g) below.
- (a) **Modulation, Pulse, On/Off** to on.
  - (b) **More, Config, Clock 40/10** to **40**, and **Top Menu**.
  - (c) **More, Mode**, arrow key to highlight **Single, Select**, and **Previous Menu**.
  - (d) **Trigger**, arrow key to highlight **Free Run, Select**, and **Previous Menu**.
  - (e) **Previous Menu, Edit Period, 1, 0, MHz ms dB**, and **Edit Period**.
  - (f) **W/D List, Edit, 5, MHz ms dB**, and **Edit**.
  - (g) **On/Off** to on.
- (10) Press spectrum analyzer keys as indicated in (a) through (g) below:
- (a) **Trig, Video, 1, 0, -dBm**.
  - (b) **BW/Avg, Video BW, 100 kHz**.
  - (c) **Res BW, 100 kHz**.
  - (d) **Sweep, Sweep Time, 5, 0, ms**.
  - (e) **BW/Avg, Average, 3, 0**.
  - (f) **Single**.
  - (g) **Peak Search**.
- (11) Verify that the marker indication is within minimum and maximum limits listed in table 18 for the 1 GHz Pulse On test.
- (12) Press spectrum analyzer **Marker, Delta** keys.
- (13) Press spectrum analyzer  $\hat{\uparrow}$  key one time. Marker should be located in the valley between the signal peaks.
- (14) Verify that the  $\Delta$ **Mkr** amplitude indicates within the limits listed in table 18 for the 1 GHz Pulse On/Off ratio.

Table 18. Pulse On/Off Ratio Test

Test description	Spectrum analyzer indication	
	Min	Max
1 GHz Pulse On	-2 dB	2 dB
1 GHz Pulse ON/OFF RATIO	----	-80 dB

- (15) Reduce outputs to minimum.
  - (16) Disconnect equipment setup.
- b. Adjustments.** No further adjustments can be made.
- 15. Final Procedure**
- a.** Deenergize and disconnect all equipment.
  - b.** Annotate and affix DA label/form in accordance with TB 750-25.

By Order of the Secretary of the Army:

Official:



JOYCE E. MORROW

*Administrative Assistant to the  
Secretary of the Army*

0719041

GEORGE W. CASEY, JR.  
*General, United States Army  
Chief of Staff*

Distribution:

To be distributed in accordance with the initial distribution number (IDN) 344717, requirements for calibration procedure TB 9-6625-2323-24.



### Instructions for Submitting an Electronic 2028

The following format must be used if submitting an electronic 2028. The subject line must be exactly the same and all fields must be included; however, only the following fields are mandatory: 1, 3, 4, 5, 6, 7, 8, 9, 10, 13, 15, 16, 17, and 27.

From: "Whomever" [whomever@redstone.army.mil](mailto:whomever@redstone.army.mil)  
To: <2028@redstone.army.mil

Subject: DA Form 2028

1. **From:** Joe Smith
2. **Unit:** home
3. **Address:** 4300 Park
4. **City:** Hometown
5. **St:** MO
6. **Zip:** 77777
7. **Date Sent:** 19-OCT -93
8. **Pub no:** 55-2840-229-23
9. **Pub Title:** TM
10. **Publication Date:** 04-JUL-85
11. **Change Number:** 7
12. **Submitter Rank:** MSG
13. **Submitter FName:** Joe
14. **Submitter MName:** T
15. **Submitter LName:** Smith
16. **Submitter Phone:** 123-123-1234
17. **Problem:** 1
18. **Page:** 2
19. **Paragraph:** 3
20. **Line:** 4
21. **NSN:** 5
22. **Reference:** 6
23. **Figure:** 7
24. **Table:** 8
25. **Item:** 9
26. **Total:** 123
27. **Text**

This is the text for the problem below line 27.







